

# Product data sheet

## Liquid ring vacuum pump

VN series

For large volumes of additional fluid

Close-coupled pumps with hub control and mechanical seal

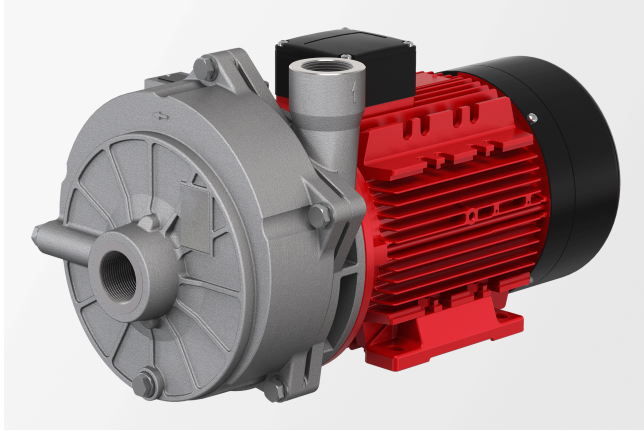

## Description

- » Liquid ring vacuum pump
- » Close-coupled pump
- » Bracket pump available on request
- » Mechanical seal
- » Designed for suction of air with high levels of water
- » Single-stage
- » With hub control
- » Valve flaps
- » Specially selected materials and seals for application-specific designs
- » Oil-free vacuum generation
- » Use of condensed process medium as the operating liquid
- » Liquid carry over at a constant vacuum

## Get in touch with us!

Speck Pumpen Vakuumtechnik GmbH  
Regensburger Ring 6-8  
91154 Roth  
Deutschland

### Make a non-binding enquiry

info@speck.de

## Markets and applications

### Plastics processing

- » Wet and dry calibration of plastic profiles

## Technical data

International system of units, alternating current 50 Hz

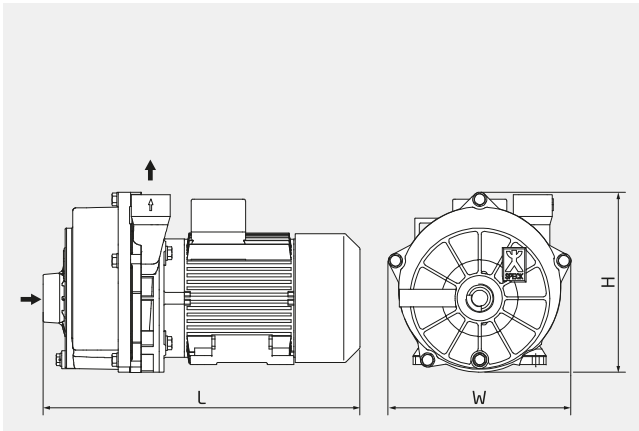

H	260-334 mm
W	310 mm
L	598-687 mm

Dimensions may vary depending on the design.

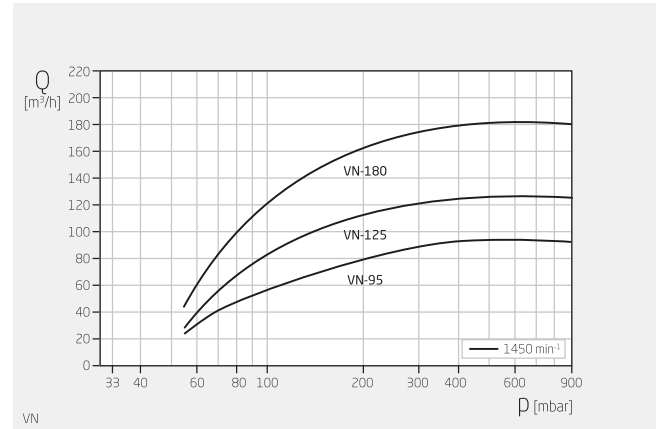

Specifications apply for dry air at 20°C at nominal speed and operating water at 15°C.

Product type	Liquid ring vacuum pump
--------------	-------------------------

Stages	1
--------	---

Shaft sealing	Mechanical seal
---------------	-----------------

Pump design	Close-coupled pump Bracket pump available on request
-------------	---

Typical media	Gas/water mixtures
---------------	--------------------

Variable speed	Frequency-converter-compatible motor on request
----------------	---

Suction pressure ext.	55-800 mbar
-----------------------	-------------

Suction capacity	25.0-180.0 m³/h
------------------	-----------------

Motor current type	3~
--------------------	----

Type of motor	Asynchronous motor
---------------	--------------------

Nominal motor power	3.0 - 5.5 kW
---------------------	--------------

Nominal motor speed	1450 rpm
---------------------	----------

Suction-side connection design	Threaded
--------------------------------	----------

Suction-side connection size	G 1½"
------------------------------	-------

Pressure-side connection design	Threaded
---------------------------------	----------

Pressure-side connection size	G 1½"
-------------------------------	-------

Material designs	Stainless steel Non-ferrous metal
------------------	--------------------------------------

Explosion protection	None II 3G, II 3D II 2G, II 2D II 2/2G
----------------------	---

## Technical data

International system of units, alternating current 60 Hz

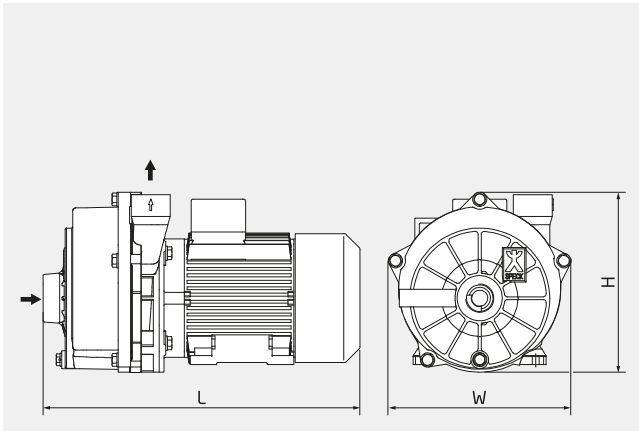

H 260-334 mm

W 310 mm

L 598-687 mm

Dimensions may vary depending on the design.

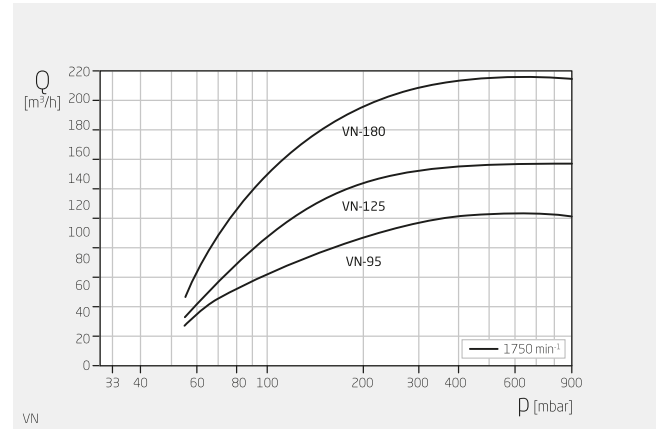

Specifications apply for dry air at 20°C at nominal speed and operating water at 15°C.

Product type	Liquid ring vacuum pump
--------------	-------------------------

Stages	1
--------	---

Shaft sealing	Mechanical seal
---------------	-----------------

Pump design	Close-coupled pump Bracket pump available on request
-------------	---

Typical media	Gas/water mixtures
---------------	--------------------

Variable speed	Frequency-converter-compatible motor on request
----------------	---

Suction pressure ext.	55-800 mbar
-----------------------	-------------

Suction capacity	30.0-216.0 m³/h
------------------	-----------------

Motor current type	3~
--------------------	----

Type of motor	Asynchronous motor
---------------	--------------------

Nominal motor power	4.6 - 8.2 kW
---------------------	--------------

Nominal motor speed	1750 rpm
---------------------	----------

Suction-side connection design	Threaded
--------------------------------	----------

Suction-side connection size	G 1½"
------------------------------	-------

Pressure-side connection design	Threaded
---------------------------------	----------

Pressure-side connection size	G 1½"
-------------------------------	-------

Material designs	Stainless steel Non-ferrous metal
------------------	--------------------------------------

Explosion protection	None II 3G, II 3D II 2G, II 2D II 2/G
----------------------	--

## Technical data

Anglo-American system of measurement, alternating current 60 Hz

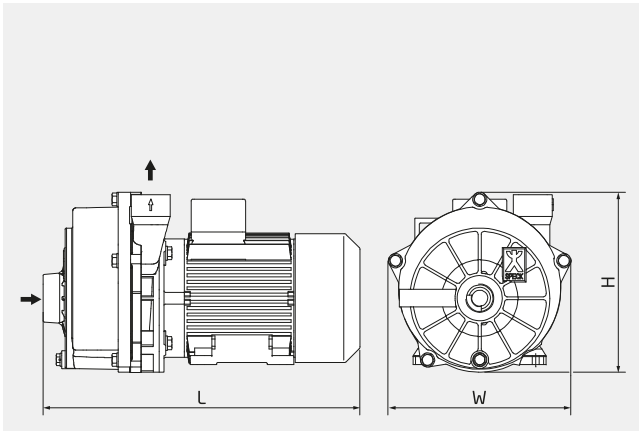

H 10,24-13,15 inch

W 12,20 inch

L 23,54-27,05 inch

Dimensions may vary depending on the design.

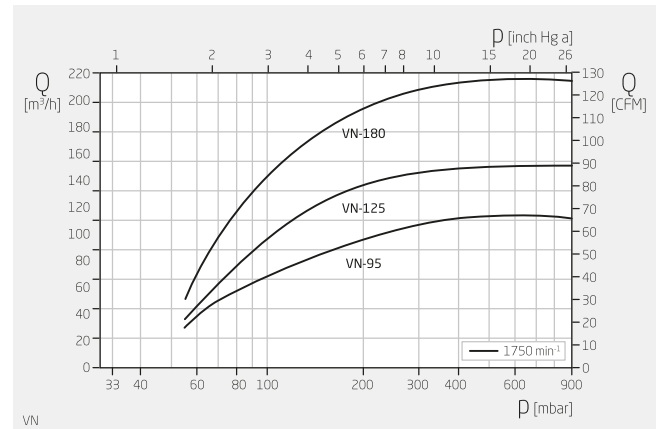

Specifications apply for dry air at 68 °F at nominal speed and operating water at 59°F.

Product type Liquid ring vacuum pump

Stages 1

Shaft sealing Mechanical seal

Pump design Close-coupled pump  
Bracket pump available on request

Typical media Gas/water mixtures

Variable speed Frequency-converter-compatible motor on request

Suction pressure ext. 1.6-23.6 inHg

Suction capacity 8.0-1552.0 m³/h

Motor current type 3~

Type of motor Asynchronous motor

Nominal motor power 6.2-11.0 HP

Nominal motor speed 1750 rpm

Suction-side connection design Threaded

Suction-side connection size G 1½"

Pressure-side connection design Threaded

Pressure-side connection size G 1½"

Material designs Stainless steel  
Non-ferrous metal

Explosion protection None  
II 3G, II 3D  
II 2G, II 2D  
II 2/2G