

Product data sheet

Regenerative turbine pump

Bracket pump with magnetic coupling

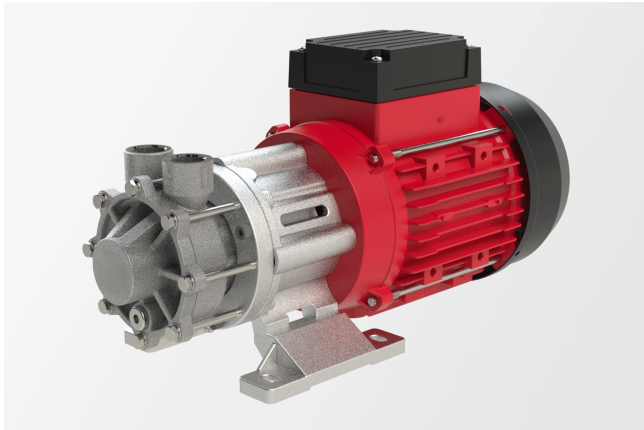

Description

- » Regenerative turbine pump
- » Bracket pump
- » Magnetic coupling
- » Hermetically sealed
- » Suitable for the delivery of gas shares
- » Steep characteristic curve

Markets and applications

Industrial cooling

- » Chillers/cooling machines
- » Cooling appliances
- » Semiconductor manufacturing
- » Industrial processes up to -100°C

Plastics processing

- » Tool tempering for injection moulding

Road and rail

- » Cooling of electrical and mechanical vehicle components, e.g. traction coolers, gearboxes and batteries

Temperature control

- » Laboratory tempering devices
- » Hot-water tempering devices
- » Oil tempering devices
- » Roller tempering
- » Tool tempering for aluminium injection moulding
- » Tool tempering for plastic injection moulding
- » Semiconductor manufacturing

Get in touch with us!

Speck Pumpen Systemtechnik GmbH
Regensburger Ring 6-8
91154 Roth
Deutschland

Make a non-binding enquiry

info@speck.de

Technical data

International system of units, alternating current 50 Hz

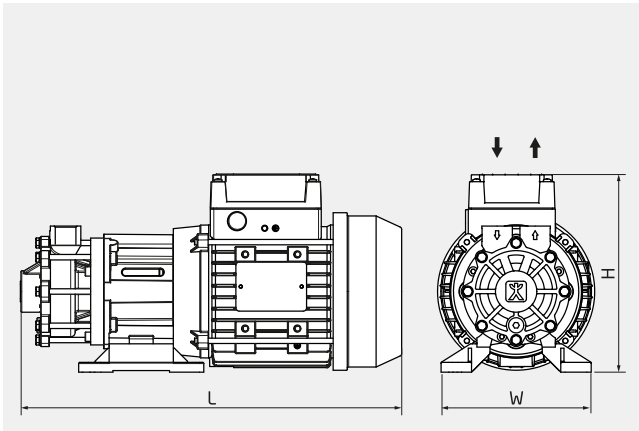

H	120-138 mm
W	120-138 mm
L	324-351 mm

Dimensions may vary depending on the design.

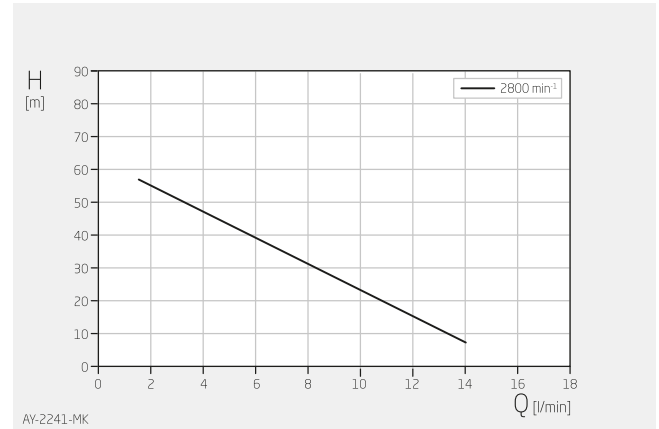

Specifications apply for water at 20°C and nominal speed.

Product type	Regenerative turbine pump
Shaft sealing/coupling	None/magnetic coupling
Pump design	Bracket pump
Typical media	Water max. +160 °C, on request max. +230 °C Oil max. +350 °C Dielectric inert fluids min. -100 °C, max. +180 °C
Self-priming	No
Variable speed	Frequency-converter-compatible motor on request
Total head	5-57 m
Flow rate	2-14 l/min
Nominal pressure	PN 16 - PN 50
Motor current type	1~/3~
Type of motor	Asynchronous motor
Nominal motor power	0.5 kW
Nominal motor speed	2900 rpm
Suction-side connection design	Thread: G, NPT, Rc/PT SAE
Suction-side connection size	G ½", SAE ½"
Pressure-side connection design	Thread: G, NPT, Rc/PT
Pressure-side connection size	G ½", SAE ½"
Material designs	Stainless steel
Explosion protection	None II 3G, II 3D II 2G, II 2D

Technical data

International system of units, alternating current 60 Hz

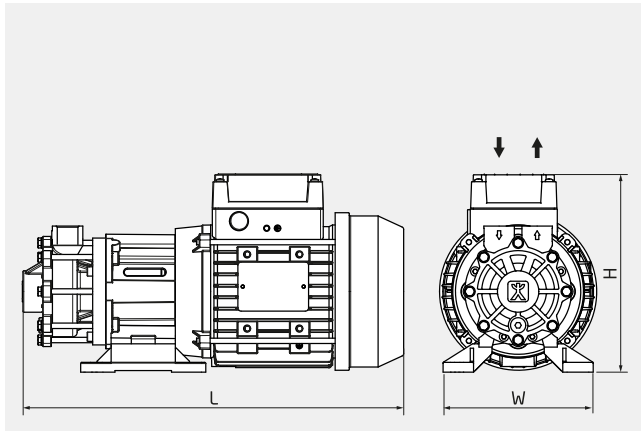

H	120-138 mm
W	120-138 mm
L	324-351 mm

Dimensions may vary depending on the design.

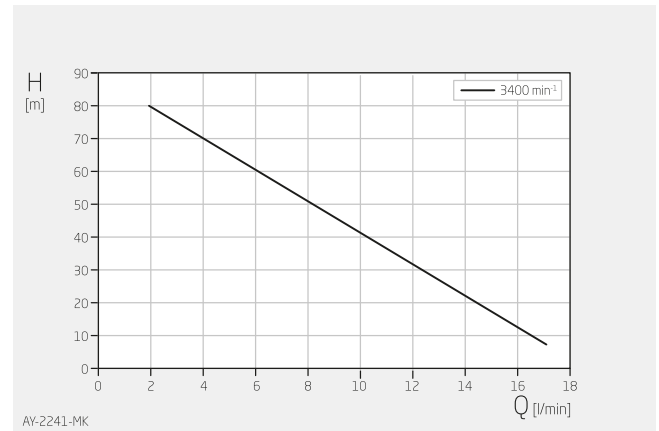

Specifications apply for water at 20°C and nominal speed.

Product type	Regenerative turbine pump
Shaft sealing/coupling	None/magnetic coupling
Pump design	Bracket pump
Typical media	Water max. +160 °C, on request max. +230 °C Oil max. +350 °C Dielectric inert fluids min. -100 °C, max. +180 °C
Self-priming	No
Variable speed	Frequency-converter-compatible motor on request
Total head	5-80 m
Flow rate	2-17 l/min
Nominal pressure	PN 16 - PN 50
Motor current type	1~/3~
Type of motor	Asynchronous motor
Nominal motor power	0.6 kW
Nominal motor speed	3500 rpm
Suction-side connection design	Thread: G, NPT, Rc/PT SAE
Suction-side connection size	G ½", SAE ½"
Pressure-side connection design	Thread: G, NPT, Rc/PT
Pressure-side connection size	G ½", SAE ½"
Material designs	Stainless steel
Explosion protection	None II 3G, II 3D II 2G, II 2D

Technical data

Anglo-American system of measurement, alternating current 60 Hz

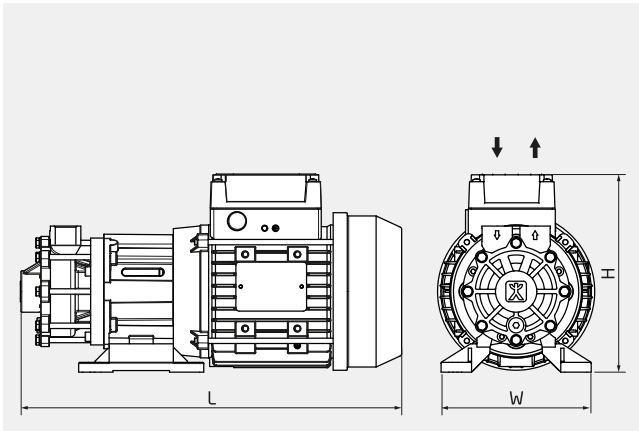

H 4,72-5,43 inch

W 4,72-5,43 inch

L 12,76-13,82 inch

Dimensions may vary depending on the design.

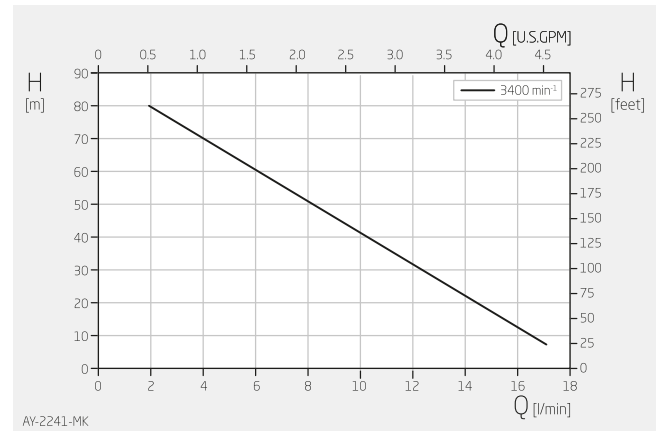

Specifications apply for water at 68°F and nominal speed.

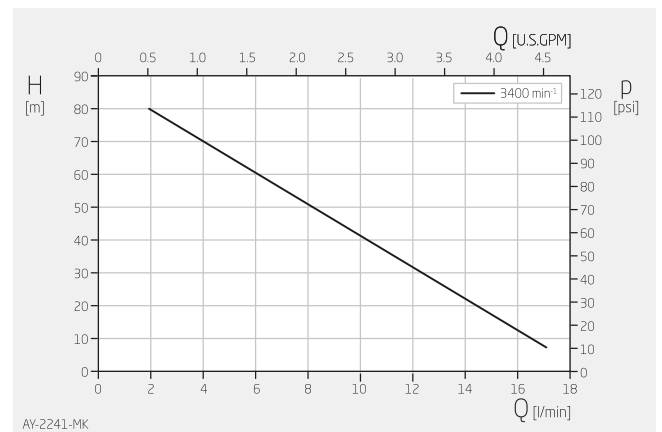

Specifications apply for water at 68°F and nominal speed.

Product type	Regenerative turbine pump
Shaft sealing/coupling	None/magnetic coupling
Pump design	Bracket pump
Typical media	Water max. +320 °F, on request max. +446 °F Oil max. +662 °F Dielectric inert fluids min. -148 °F, max. +356 °F
Self-priming	No
Variable speed	Frequency-converter-compatible motor on request
Total head	16-262 ft
Flow rate	0.5-4.5 USGPM
Nominal pressure	PN 16 - PN 50
Motor current type	1~/3~
Type of motor	Asynchronous motor
Nominal motor power	0.8 HP
Nominal motor speed	3500 rpm
Suction-side connection design	Thread: G, NPT, Rc/PT SAE
Suction-side connection size	G ½", SAE ½"
Pressure-side connection design	Thread: G, NPT, Rc/PT
Pressure-side connection size	G ½", SAE ½"
Material designs	Stainless steel
Explosion protection	None II 3G, II 3D II 2G, II 2D