

Product data sheet

Regenerative turbine pump

Close-coupled pump with mechanical seal

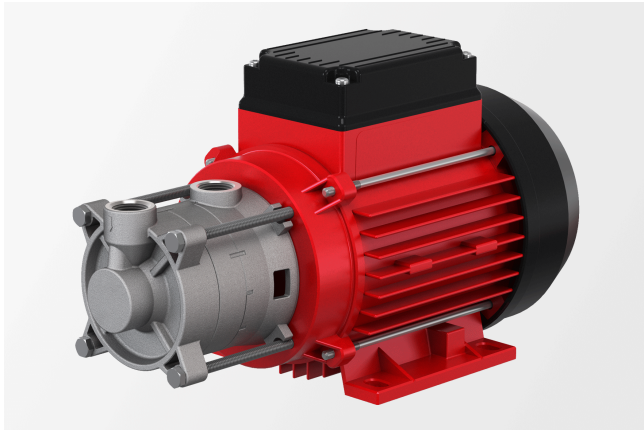

Description

- » Regenerative turbine pump
- » Close-coupled pump
- » Mechanical seal
- » Two-stage
- » Suitable for the delivery of gas shares
- » High pressures with a compact design
- » Steep characteristic curve

Markets and applications

Industrial cooling

- » Chillers/cooling machines
- » Cooling appliances

Food and beverage industry

- » Beverage filling plants
- » Reverse osmosis systems

Temperature control

- » Laboratory tempering devices
- » Hot-water tempering devices
- » Oil tempering devices

Get in touch with us!

Speck Pumpen Walter Speck GmbH & Co. KG
Regensburger Ring 6-8
91154 Roth
Deutschland

Make a non-binding enquiry

info@speck.de

Technical data

International system of units, alternating current 50 Hz

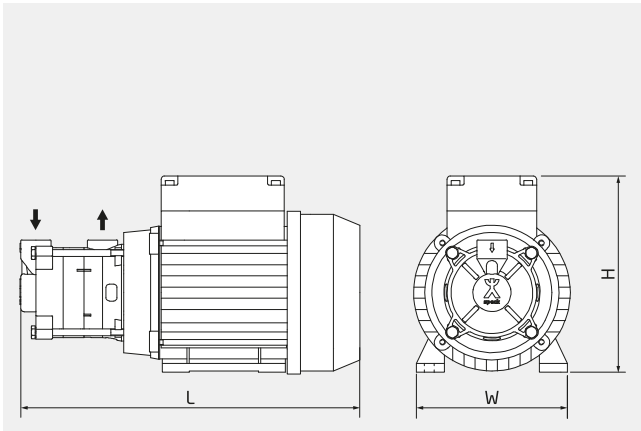

H	175 mm
W	135 mm
L	304 mm

Dimensions may vary depending on the design.

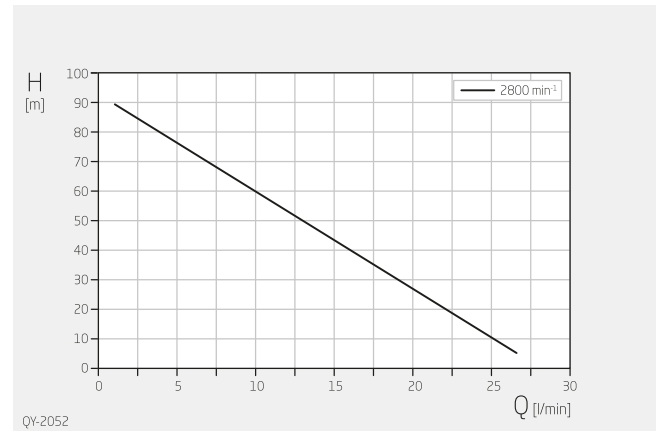

Specifications apply for water at 20°C and nominal speed.

Product type	Regenerative turbine pump
Shaft sealing	Mechanical seal
Pump design	Close-coupled pump
Typical media	Water max. +140 °C Oil max. +160 °C
Self-priming	No
Variable speed	Frequency-converter-compatible motor on request
Total head	5-90 m
Flow rate	1-26 l/min
Nominal pressure	PN 16
Motor current type	3~
Type of motor	Asynchronous motor
Nominal motor power	0.75 - 1.1 kW
Nominal motor speed	2800 rpm
Suction-side connection design	Threaded
Suction-side connection size	G 1/2"
Pressure-side connection design	Threaded
Pressure-side connection size	G 1/2"
Material designs	Stainless steel
Explosion protection	None

Technical data

International system of units, alternating current 60 Hz

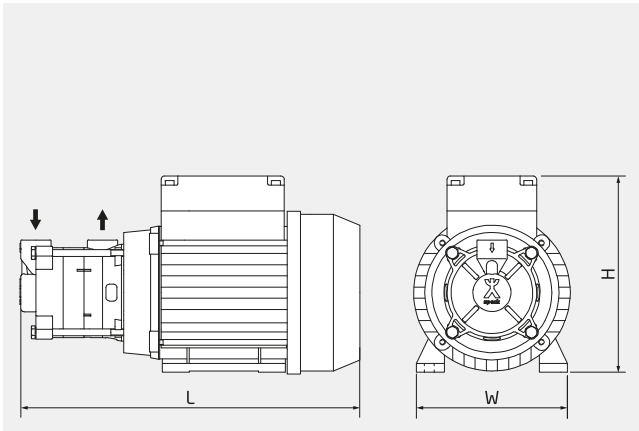

H 175 mm

W 135 mm

L 304 mm

Dimensions may vary depending on the design.

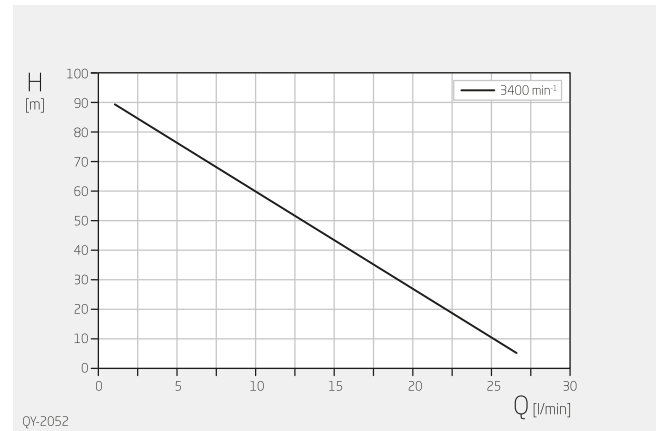

Specifications apply for water at 20°C and nominal speed.

Product type	Regenerative turbine pump
Shaft sealing	Mechanical seal
Pump design	Close-coupled pump
Typical media	Water max. +140 °C Oil max. +160 °C
Self-priming	No
Variable speed	Frequency-converter-compatible motor on request
Total head	5-90 m
Flow rate	1-26 l/min
Nominal pressure	PN 16
Motor current type	3~
Type of motor	Asynchronous motor
Nominal motor power	0.75 - 1.1 kW
Nominal motor speed	3400 rpm
Suction-side connection design	Threaded
Suction-side connection size	G 1/2"
Pressure-side connection design	Threaded
Pressure-side connection size	G 1/2"
Material designs	Stainless steel
Explosion protection	None

Technical data

Anglo-American system of measurement, alternating current 60 Hz

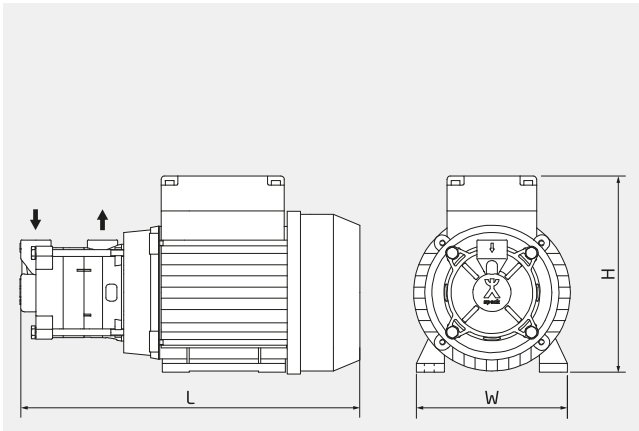

H 6,89 inch

W 5,31 inch

L 11,97 inch

Dimensions may vary depending on the design.

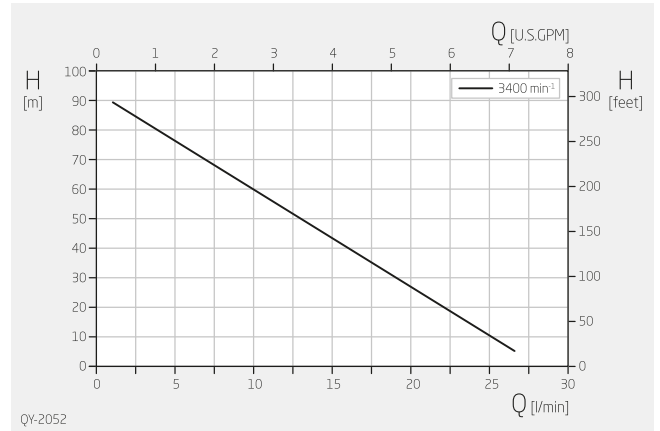

Specifications apply for water at 68°F and nominal speed.

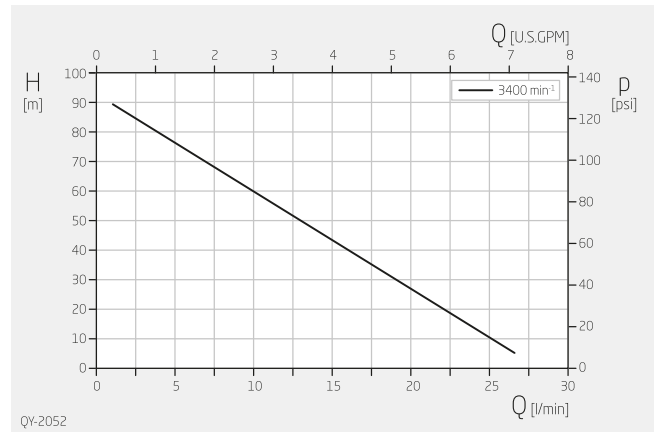

Specifications apply for water at 68°F and nominal speed.

Product type	Regenerative turbine pump
Shaft sealing	Mechanical seal
Pump design	Close-coupled pump
Typical media	Water max. +284 °F Oil max. +320 °F
Self-priming	No
Variable speed	Frequency-converter-compatible motor on request
Total head	16-295 ft
Flow rate	0.3-6.9 USGPM
Nominal pressure	PN 16
Motor current type	3~
Type of motor	Asynchronous motor
Nominal motor power	1.0 – 1.5 HP
Nominal motor speed	3400 rpm
Suction-side connection design	Threaded
Suction-side connection size	G ½"
Pressure-side connection design	Threaded
Pressure-side connection size	G ½"
Material designs	Stainless steel
Explosion protection	None